

3-R 90° ELBOWS

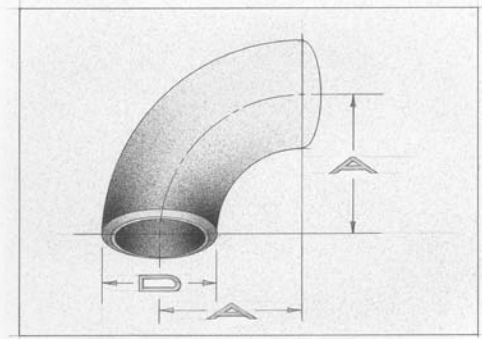

Key			Nominal Wall Thickness: inches mm Inside Diameter: inches mm Approximate Weight: Pounds (see page 3 for Kg)													
			Schedule													
Nominal Pipe Size	"D" Outside Diameter at Bevel	"B" Center-to-End	L.W.G.	10	20	30	40	STD WT	60	XS	80	100	120	140	160	XXS
inches mm	inches mm	inches mm														
¾"	1.05	2.25	-	-	-	-	.113	.113	-	.154	.154	-	-	-	.219	.308
			-	-	-	-	2.870	2.870	-	3.912	3.912	-	-	-	5.563	7.823
			-	-	-	-	.824	.824	-	.742	.742	-	-	-	.612	.434
			-	-	-	-	20.930	20.930	-	18.847	18.847	-	-	-	15.545	11.024
			-	-	-	-	0.2	0.2	-	0.3	0.3	-	-	-	0.6	0.3
1"	1.32	3.0	-	-	-	-	.133	.133	-	.179	.179	-	-	-	.250	.358
			-	-	-	-	3.378	3.378	-	4.547	4.547	-	-	-	6.350	9.093
			-	-	-	-	1.049	1.049	-	.957	.957	-	-	-	.815	.599
			-	-	-	-	26.645	26.645	-	24.308	24.308	-	-	-	20.701	15.215
			-	-	-	-	0.4	0.4	-	0.5	0.5	-	-	-	0.6	0.8
1¼"	1.66	3.75	-	-	-	-	.140	.140	-	.191	.191	-	-	-	.250	.382
			-	-	-	-	3.556	3.556	-	4.851	4.851	-	-	-	6.350	9.703
			-	-	-	-	1.380	1.380	-	1.278	1.278	-	-	-	1.160	.896
			-	-	-	-	35.052	35.052	-	32.461	32.461	-	-	-	29.464	22.758
			-	-	-	-	0.6	0.6	-	0.8	0.8	-	-	-	1.0	1.4
1½"	1.90	4.50	-	-	-	-	.145	.145	-	.200	.200	-	-	-	.281	.400
			-	-	-	-	3.683	3.683	-	5.080	5.080	-	-	-	7.137	10.160
			-	-	-	-	1.610	1.610	-	1.500	1.500	-	-	-	1.338	1.100
			-	-	-	-	40.894	40.894	-	38.100	38.100	-	-	-	33.985	27.940
			-	-	-	-	0.8	0.8	-	1.0	1.0	-	-	-	1.8	2.0
2"	2.38	6.00	-	-	-	-	.154	.154	-	.218	.218	-	-	-	.344	.436
			-	-	-	-	3.912	3.912	-	5.537	5.537	-	-	-	8.738	11.074
			-	-	-	-	2.067	2.067	-	1.939	1.939	-	-	-	1.687	1.503
			-	-	-	-	52.502	52.502	-	49.251	49.251	-	-	-	42.850	38.176
			-	-	-	-	1.6	1.6	-	2.0	2.0	-	-	-	3.2	3.9
2½"	2.88	7.50	-	-	-	-	.203	.203	-	.276	.276	-	-	-	.375	.552
			-	-	-	-	5.156	5.156	-	7.010	7.010	-	-	-	9.525	14.021
			-	-	-	-	2.469	2.469	-	2.323	2.323	-	-	-	2.125	1.771
			-	-	-	-	62.713	62.713	-	59.004	59.004	-	-	-	53.975	44.983
			-	-	-	-	2.9	2.9	-	4.0	4.0	-	-	-	6.0	6.8
3"	3.50	9.0	-	-	-	-	.216	.216	-	.300	.300	-	-	-	.438	.600
			-	-	-	-	5.486	5.486	-	7.620	7.620	-	-	-	11.125	15.240
			-	-	-	-	3.068	3.068	-	2.900	2.900	-	-	-	2.624	2.300
			-	-	-	-	77.927	77.927	-	73.660	73.660	-	-	-	66.650	58.420
			-	-	-	-	4.6	4.6	-	6.3	6.3	-	-	-	10.0	11.3
4"	4.50	12.00	.188	-	-	-	.237	.237	-	.337	.337	-	-	.438	.531	.674
			4.775	-	-	-	6.020	6.020	-	8.560	8.560	-	11.125	13.487	17.120	
			4.124	-	-	-	4.026	4.026	-	3.826	3.826	-	3.624	3.438	3.152	
			104.749	-	-	-	102.260	102.260	-	97.180	97.180	-	92.050	87.325	80.061	
			7.8	-	-	-	8.7	8.7	-	12.2	12.2	-	15.0	22.0	23.0	

*Not given in ASME B36.10

3-R 90° ELBOWS

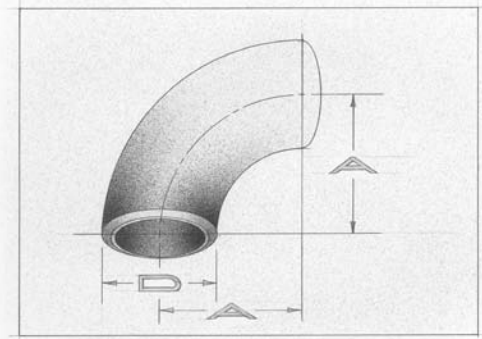

Key			Nominal Wall Thickness: inches mm Inside Diameter: inches mm Approximate Weight: Pounds (see page 3 for Kg)													
			Schedule													
Nominal Pipe Size	"D" Outside Diameter at Bevel	"B" Center-to-End	L.W.G.	10	20	30	40	STD WT	60	XS	80	100	120	140	160	XXS
inches mm	inches mm	inches mm														
6"	6.63	18.0	.219	-	-	-	.280	.280	-	.432	.432	-	.562	-	.719	.864
			5.563	-	-	-	7.112	7.112	-	10.973	10.973	-	14.275	-	18.263	21.946
			6.187	-	-	-	6.065	6.065	-	5.761	5.761	-	5.501	-	5.187	4.897
152.40	168.28	457.2	157.150	-	-	-	154.051	154.051	-	146.329	146.329	-	139.725	-	131.750	124.384
			19.5	-	-	-	23.7	23.7	-	33.5	33.5	-	44.0	-	62.0	69.0
8"	8.63	24.0	.219	-	.250	.277	.322	.322	.406	.500	.500	.594	.719	.812	.906	.875
			5.563	-	6.350	7.036	8.179	8.179	10.312	12.700	12.700	15.088	18.263	20.625	23.012	22.225
			8.187	-	8.125	8.071	7.981	7.981	7.813	7.625	7.437	7.187	7.001	6.813	6.875	
203.20	219.08	609.6	207.949	-	206.375	205.003	202.717	202.717	198.450	193.675	193.675	188.900	182.550	177.825	173.050	174.625
			30.3	-	38.3	41.8	45.8	45.8	58.0	70.0	70.0	85.5	103.0	116.0	122.0	120.0
10"	10.75	30.0	.219	-	.250	.307	.365	.365	.500	.500	.594	.719	.844	1.000	1.125	1.000
			5.563	-	6.350	7.798	9.271	9.271	12.700	12.700	15.088	18.263	21.438	25.400	28.575	25.400
			10.312	-	10.250	10.136	10.020	10.020	9.750	9.750	9.562	9.312	9.062	8.750	8.500	8.750
254.00	273.05	762.0	261.925	-	260.350	257.454	254.508	254.508	247.650	247.650	242.875	236.525	230.175	222.250	215.900	222.250
			-	-	59.0	68.4	86.0	86.0	107.0	109.0	130.0	164.0	201.0	232.0	270.0	232.0
12"	12.75	36.0	.250	-	.250	.330	.406	.375	.562	.500	.688	.844	1.000	1.125	1.312	1.000
			6.350	-	6.350	8.382	10.312	9.525	14.275	12.700	17.475	21.438	25.400	28.575	33.325	25.400
			12.250	-	12.250	12.090	11.938	12.000	11.626	11.750	11.374	11.062	10.750	10.500	10.126	10.750
304.80	323.85	914.40	311.150	-	311.150	307.086	303.225	304.800	295.300	298.450	288.900	280.975	273.050	266.700	257.200	273.050
			-	-	96.0	105.0	129.0	120.0	180.0	160.0	210.0	269.0	315.0	365.0	460.0	315.0
16"	16.00	48.0	.250	.250	.312	.375	.500	.375	.656	.500	.844	1.031	1.219	1.438	1.594	-
			6.350	6.350	7.925	9.525	12.700	9.525	16.662	12.700	21.438	26.187	30.963	36.525	40.488	-
			15.500	15.500	15.376	15.250	15.000	15.250	14.688	15.000	14.312	13.938	13.562	13.124	12.812	-
406.40	406.40	1219.2	393.700	393.700	390.550	387.350	381.000	387.350	373.075	381.000	363.525	354.025	344.475	333.350	325.425	-
			135.0	135.0	169.0	-	262.0	206.0	302.0	268.0	420.0	518.0	622.0	735.0	825.0	-
18"	18.00	154.0	.250	.250	.312	.438	.562	.375	.750	.500	.938	1.156	1.375	1.562	1.781	-
			6.350	6.350	7.925	11.125	14.275	9.525	19.050	12.700	23.825	29.362	34.925	39.675	45.237	-
			17.500	17.500	17.376	17.124	16.876	17.250	16.500	17.000	16.124	15.688	15.250	14.876	14.438	-
457.20	457.20	1371.6	444.500	444.500	441.350	434.950	428.650	438.150	419.100	431.800	409.550	398.475	387.350	377.850	366.725	-
			165.0	165.0	215.0	287.0	369.0	256.0	512.0	318.0	620.0	747.0	872.0	1005.0	-	
20"	20.00	60.0	.250	.250	.375	.500	.594	.375	.812	.500	1.031	1.281	1.500	1.750	1.969	-
			6.350	6.350	9.525	12.700	15.088	9.525	20.625	12.700	26.187	32.537	38.100	44.450	50.013	-
			19.500	19.500	19.250	19.000	18.812	19.250	18.376	19.000	17.938	17.438	17.000	16.500	16.062	-
508.00	508.00	1524.0	495.300	495.300	488.950	482.600	477.825	488.950	466.750	482.600	455.625	442.925	431.800	419.100	407.975	-
			194.0	194.0	310.0	409.0	498.0	344.0	675.0	407.0	840.0	997.0	1178.0	1419.0	-	
24"	24.00	72.0	.250	.250	.375	.562	.688	.375	.969	.500	1.219	1.531	1.812	2.062	2.344	-
			6.350	6.350	9.525	14.275	17.475	9.525	24.613	12.700	30.963	38.887	46.025	52.375	59.538	-
			23.500	23.500	23.250	22.876	22.624	23.250	22.062	23.000	21.562	20.938	20.376	19.876	19.312	-
609.60	609.60	1828.8	596.900	596.900	590.550	581.050	574.650	590.550	560.375	584.200	547.675	531.825	517.550	504.850	490.525	-
			304.0	304.0	-	691.0	844.0	483.3	1170.0	632.0	1465.0	1730.0	2050.0	2310.0	-	